



E-Skylight, Inc.

**Skylight
Installation & Maintenance
Manual
For
Field Assembled Pyramid Skylights**

**E-Skylight, Inc.
PO Box 830
Branford, CT 06405
Tel. (866) 624-3759
Fax. (207) 636-8004
www.e-skylight.com**

IMPORTANT NOTICE:

**PLEASE READ THE ASSEMBLY
INSTRUCTIONS THOROUGHLY PRIOR TO
BEGINNING SKYLIGHT INSTALLATION.
FAILURE TO COMPLY WITH ALL
ASSEMBLY INSTRUCTIONS AND
PROCEDURES WILL VOID THE WARRANTY
AND MAY RESULT IN PERSONAL INJURY
OR DEATH.**

Table of Contents:

	Page #
General Installation Guidelines	4
General Notes	4
Safety	4
Material Storage	4
Material Handling	5
Job Site	5
Weather Conditions	5
Tools Required	6
Materials Not Included	6
E-Skylight Components	7
Base Plates / Sills	7
Rafters / Purlins	8
Hips / Ridges	9
Caps / Closures / Misc.	10
Hardware	11
Exploded View of Pyramid	13
Step By Step Assembly Procedure	14
Step #1 - Curb Layout	14
Step #2 – Sill / Base Plates / Anchoring	15
Step #3 – Hip Rafter Attachment	20
Step #4 – Rafter / Purlin Attachment	23
Step #5 – Glazing	25
Step #6 – Sealing	27
Step #7 – Caps and Closures	30
Step #8 – Flashing	32
List of Appendicies	36

General Installation Guidelines:

General Notes:

1. Please familiarize yourself with your shop drawings prior to receiving your skylight and have your shop drawings (8.5" x 11" details included with your order) available when installing your skylight.
2. The hardware referenced in this manual is also referenced in your detail package. Please be sure to use the correct fasteners and sealants to insure quick and easy assembly and to insure proper performance of your skylight.
3. Actual components on your skylight may vary based upon the skylight size and design. See detailed shop drawings for actual extrusions and hardware used on your skylight. Components which may vary are referred in the installation instructions as well as the piece mark drawings as "xxx" components. For example, a sill extrusion referred to as "Sxxx" on assembly diagrams may be a S201, S401 or S501 depending on the specific requirements for your skylight and are clearly marked on your shop drawings.

Safety:

Skylight installation generally involves working on a roof near an opening in the roof, and is therefore inherently dangerous. There are risks of personal injury to oneself by falling, or to others on the ground by falling material, tools, or supplies. Before attempting any skylight installation obtain all personal safety protection equipment in accordance with OSHA guidelines. Whenever working on the roof you must always tie off using this equipment to ensure your personal safety. Always wear a full-length shirt, pants, gloves, and hardhat to protect against the potential of cuts from sharp edges of metal or glass.

Material Storage:

Material should be kept at a convenient but, safe distance from the roof opening and on a flat secure surface. This is a safety issue as you can lose your balance stepping on or over poorly located materials. Materials not stored on a flat and secure surface can easily fall off the roof causing a safety risk to you and others. Glass is an especially dangerous material to store and handle, due to its weight (up to 2000 pounds per box) and the potential for breakage and sharp edges. Glass must always be stored upright in its original shipping container, and the container must always be braced to ensure its stability. The container must be leaned back at 10 degrees and braced prior to opening to ensure the glass in the box will not all fall out at once. Refer to GANA Manual (Appendix "B").

Material Handling:

Handling of skylight materials is a safety concern. It is important to have sufficient personnel, and or equipment available to handle the skylight components. For example, the aluminum frame components can be long, heavy, and awkward for movement by only one person. They can also have sharp edges from machining. Glass requires special equipment for safe handling due to its weight and fragility. Glazing cups should be used to move or set all glass. For larger pieces, those exceeding 15 square feet, a crane or other lifting device is recommended. When installing pre-assembled units a crane is absolutely required. See GANA manual (Appendix "B") for other suggested equipment.

Job Site:

For a safe and efficient skylight installation, tools and materials must be kept in neat order. Packaging materials, used rags, tools, hardware etc., should all be promptly and properly disposed of to ensure personal safety, the safety of others and to protect against roof punctures or skylight damage.

Weather Conditions:

Weather conditions have an important impact on the safety and effectiveness of your skylight installation. Do not attempt a skylight installation under adverse weather conditions. Not only is glass and aluminum extremely slippery when wet, silicone will not adhere properly to a wet surface.

Tools Required:

Safety Glasses	Framing Square	Chalk Line
Socket Set	Drill and Drill Bits (Std, Phillips & Square)	Tape Measure
Wrenches	Caulking Gun (10.3 oz tubes)	Pop Rivet Gun
Electric Drill	Electric Screw Gun	Rubber Mallet
Caulking Tools	Level, Transit	Utility Knife
Sheet Metal Snips	Glass Scraper	Glass Cups
Claw Hammer	Pry Bar	

Materials Not Included With Skylight:

Curb Construction/Material	Roofing Material	Rags/Cleaning Towels
Glass Cleaner	Masking Tape	Isopropyl Alcohol

E-SKYLIGHT COMPONENTS

(Sills and Base plates)

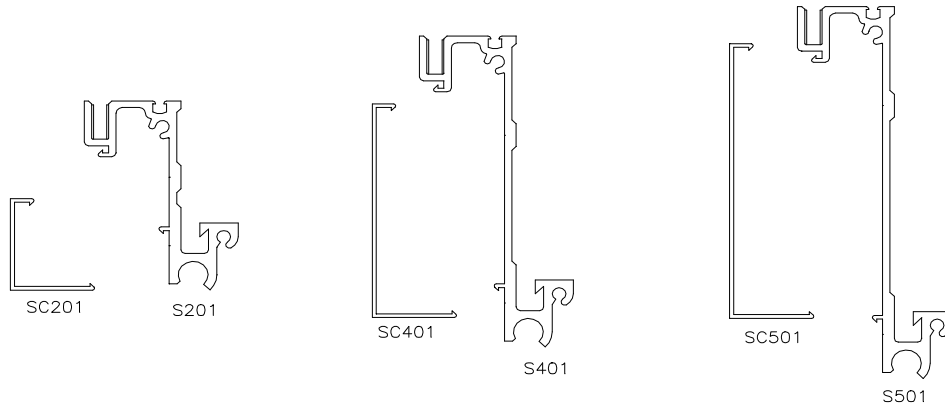

SILLS / SILL COVERS



BASE PLATES

E-SKYLIGHT COMPONENTS

(Rafters, Mullions and Purlins)

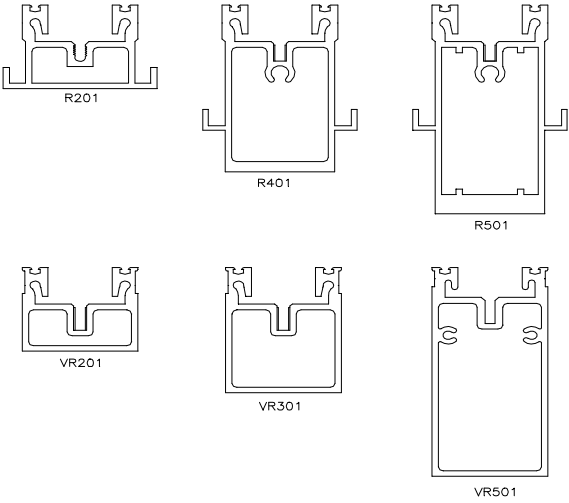

RAFTERS / MULLIONS

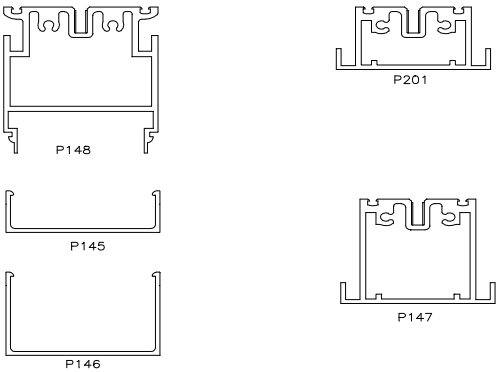

PURLINS

E-SKYLIGHT COMPONENTS

(Hip Rafters and Ridges)

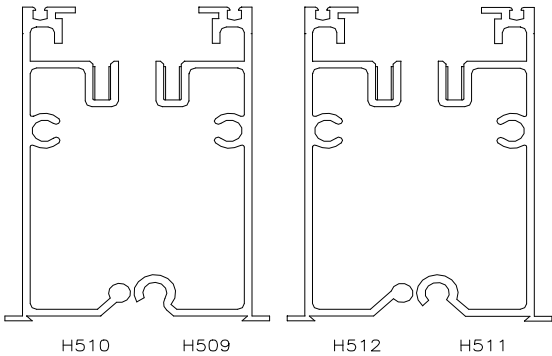
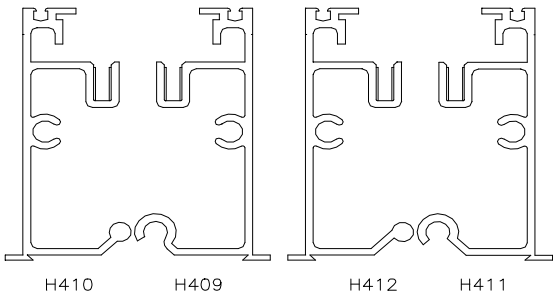
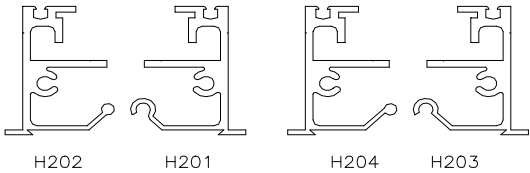

HIPS / RIDGES

E-SKYLIGHT COMPONENTS

(Miscellaneous Extrusions)

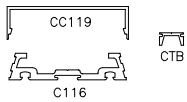

CAPS / CLOSURES

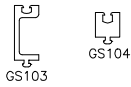

ADAPTORS

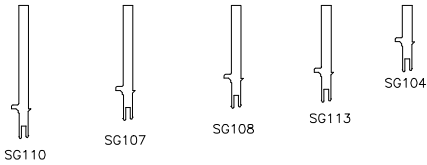

GLAZING SUPPORTS

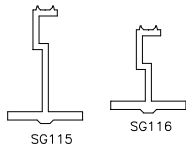

CAP STEMS

E-SKYLIGHT COMPONENTS (Hardware)

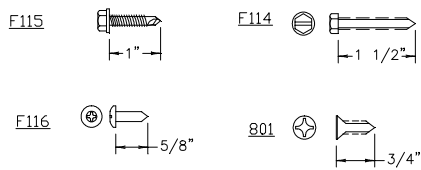
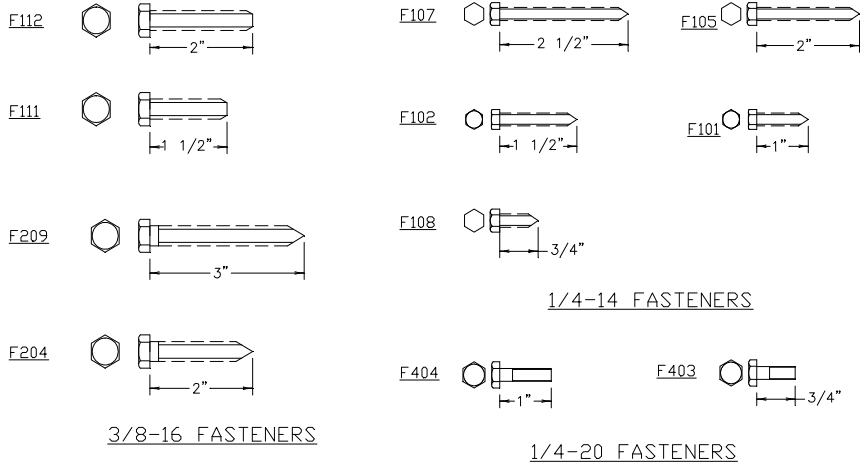

MISC FASTENERS

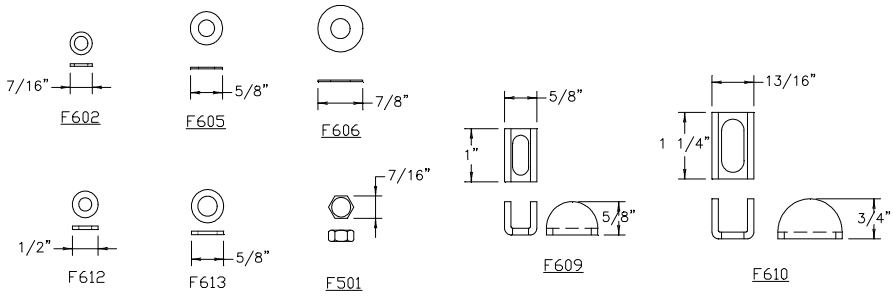

WASHERS AND NUTS

E-SKYLIGHT COMPONENTS (Hardware)

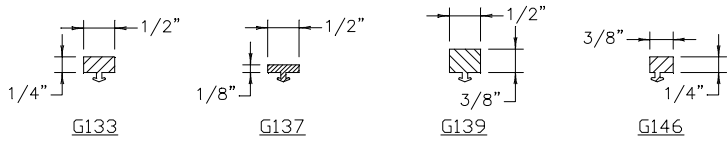

GASKETS

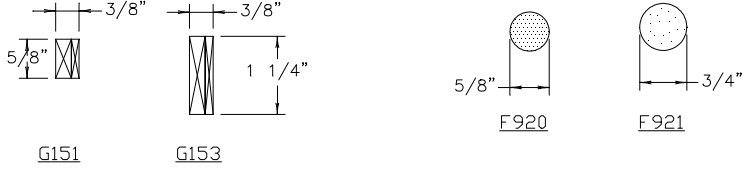

GLASS SETTING BLOCKS

BACKER RODS

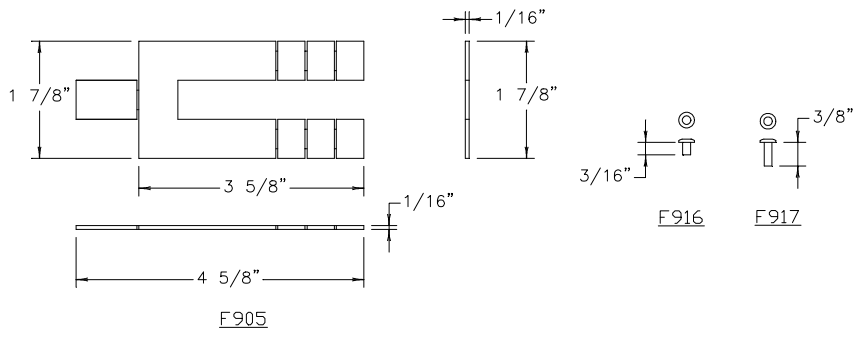

SHIM

POP RIVETS

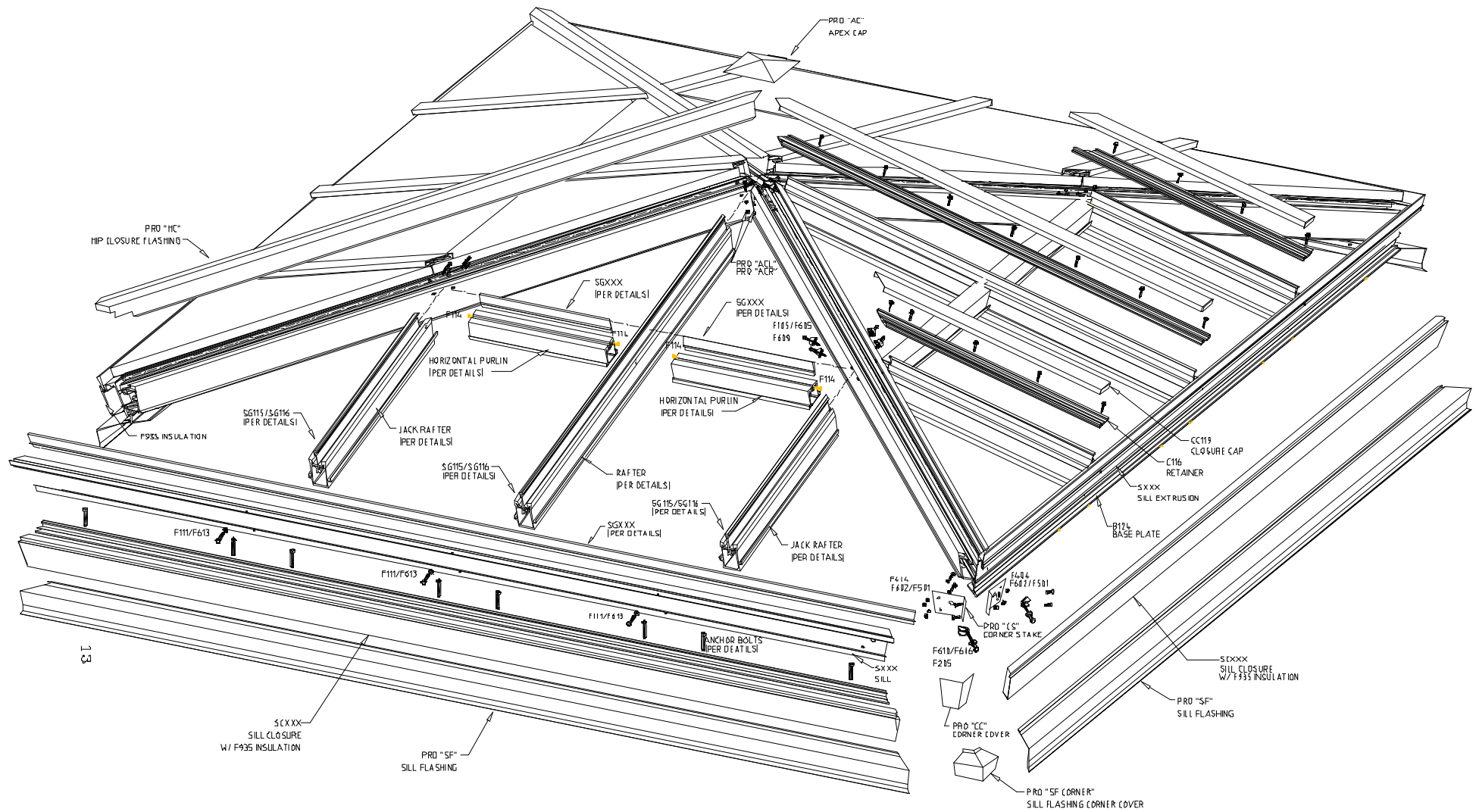

Exploded View of Pyramid

Step by step Assembly Procedure:

STEP #1: Curb Layout

The curb construction must be verified as sufficient to withstand the design loads imposed by the skylight and weather conditions. Please note that the standard design loads are listed on detail pages of your shop drawing set. E-Skylight.com, Inc. cannot be held responsible for the installation of a skylight on a curb that does not meet or exceed these design criteria. This verification by the skylight purchaser and installer with the curb manufacturer is essential to ensure proper installation as an under designed curb is a safety and performance problem.

The curb must be accurately measured for proper dimensions, squareness, and levelness prior to installation. This is required to ensure ease and accuracy of installation as well as future performance. Measure the actual curb dimensions to determine if your skylight will fit or if the curb will require modifications. Check the diagonal measurements of the curb to for squareness. Use a laser level or a transit to locate the “high spot” on the curb. The shimming of all points of attachment is based on the difference in elevation from this point. Note that shimming cannot exceed 1/2”, so curbs with a variation in excess of this amount must be modified prior to attaching the skylight.

1. Measure curb dimensions prior to beginning installation. Check dimensions of finished curb for level as well as dimensional accuracy. Curb must be within 1/2”+₋ of level and perimeter dimensions must be within 1/8”+₋ of specified curb dimensions (See Diagram #1).

2. Check diagonal dimensions of curb. This should be done at the outside to outside points of the finished curb “out to out of curb” (see Diagram #1).

IMPORTANT NOTE:

Diagonal dimensions must be equal for skylight to fit properly!!!

$$\text{Diagonal Dim (c): } c^2 = a^2 + b^2$$

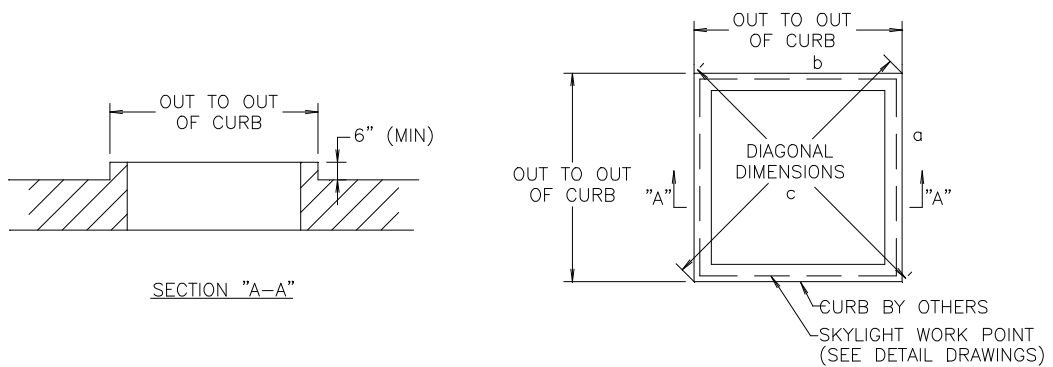

Diagram #1 – Checking curb for Square

STEP #2: Sill and Base Plate Assembly

The skylight is anchored to the curb by attaching the base plates to the curb with the fasteners provided. Before assembling the sills, slide the base plates into the appropriate sill as shown.

1. Slide base plates(B124) onto sills(Sxxx) (see Diagram #2 and 2A).

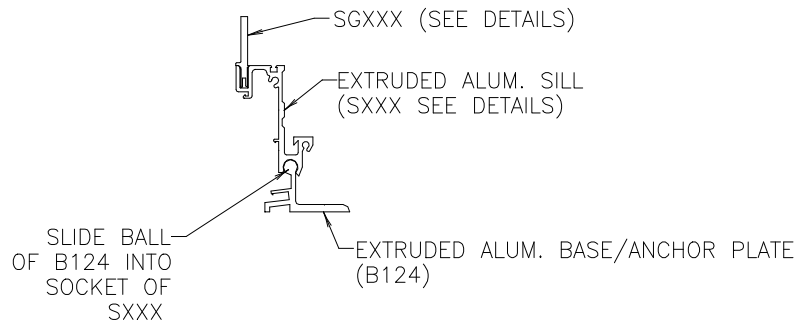

Diagram #2 – Attaching sill base plates

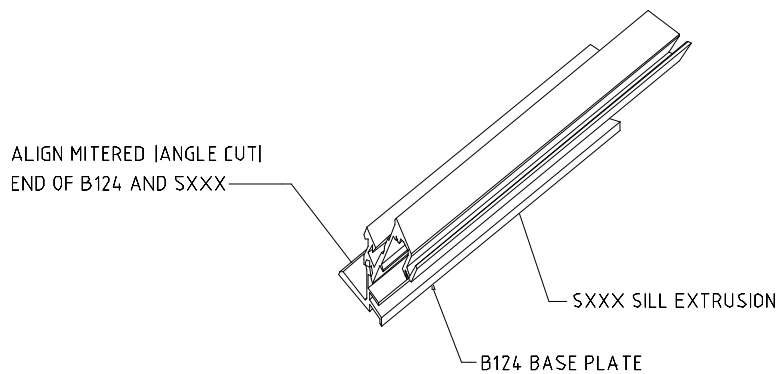

Diagram #2A – Attaching sill base plates
(non-pre-assembled units)

2. Attach sill corner stake (Pro “CS”) to each end of sills using hardware provided (F404/F605/F602/F502). See Diagram #3.

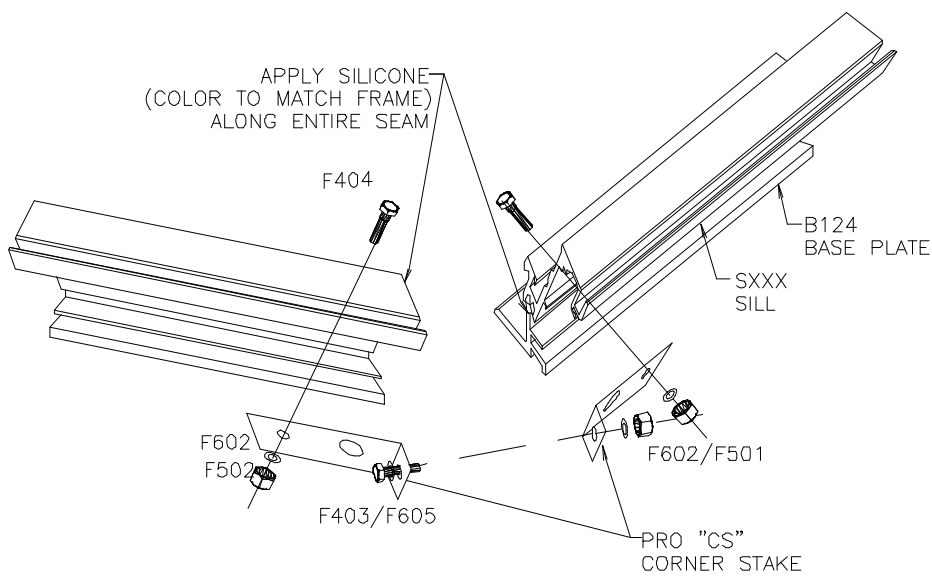
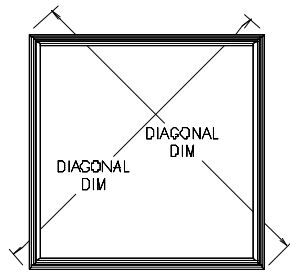
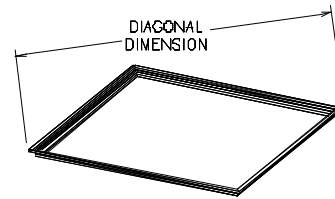

Diagram #3 – Attaching sill corner stakes

3. Align sill corner stakes to allow for through bolting. Attach all four corners before tightening bolts completely. After tightening bolts, check diagonal dimensions of sills for equality (see Diagram #3A).



PLAN VIEW



ISOMETRIC VIEW

Diagram #3A – Checking sills for square

IMPORTANT NOTE:

Diagonal dimensions of sills must be equal (+- 1/16") before continuing.

4. When diagonal dimensions are equal bolt sills tightly and proceed to step 5.

Refer to diagram #3 for bolting.

- Center sill assembly on curb so that the base plates are equal distances from outside of curb (see Diagram #4).

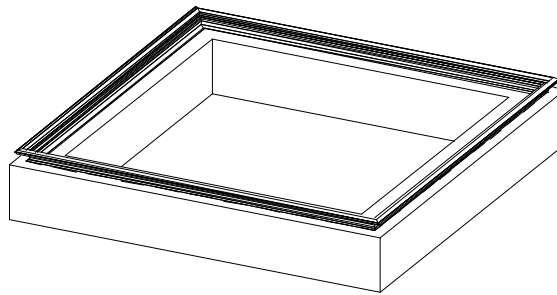
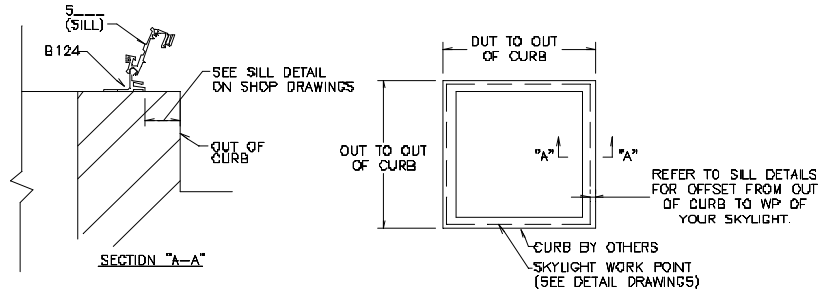

ISOMETRIC VIEW OF SILL ASSEMBLY ON CURB

Diagram #4 – Align skylight on curb

- Important Note: Check silicone at joint between SXXX (sills) and B124 (base plates) prior to anchoring skylight to curb. Re-check diagonal dimensions often to maintain square sills. Next, proceed to anchor the skylight to the curb with the fasteners provided (see shop drawings).

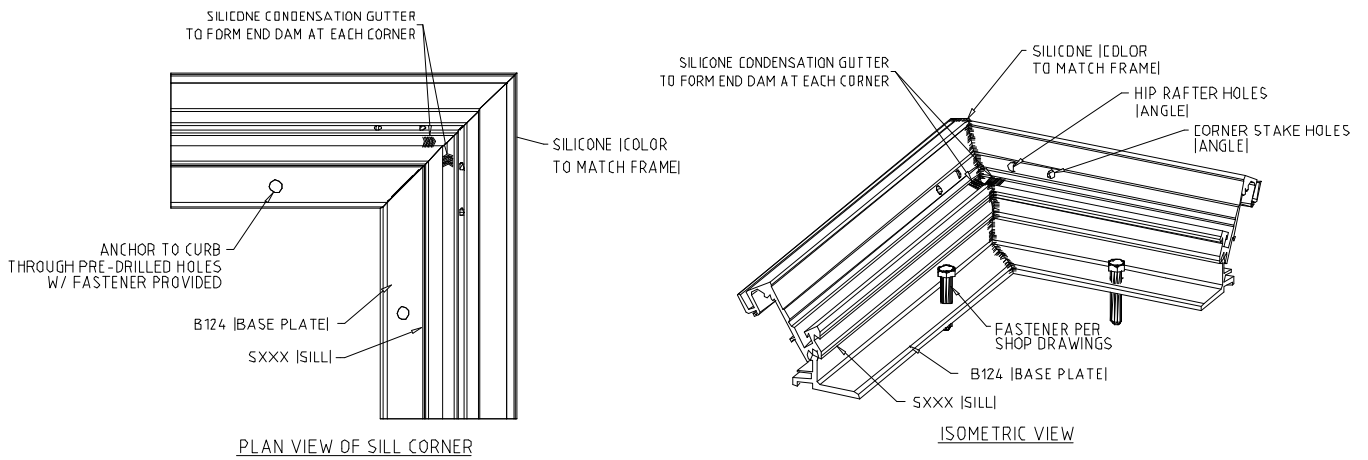

Diagram #4A – Sealing Frame Corners @ Sills

STEP #3: Hip Rafter Attachment

1. Set Hip Rafters (HXXX/HXXX)(pre assembled) into sill assembly. Align hips at apex and attach using apex clips (Pro “ACL/R”) (see Diagram #5 & 5A).

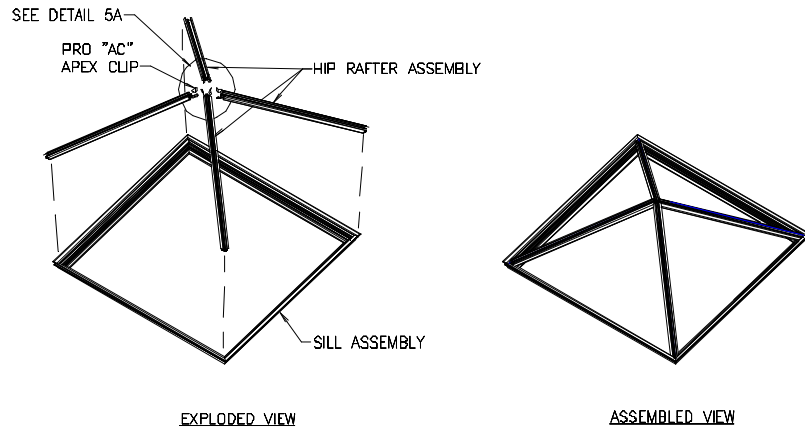

Diagram #5 – Hip rafter attachment @ apex

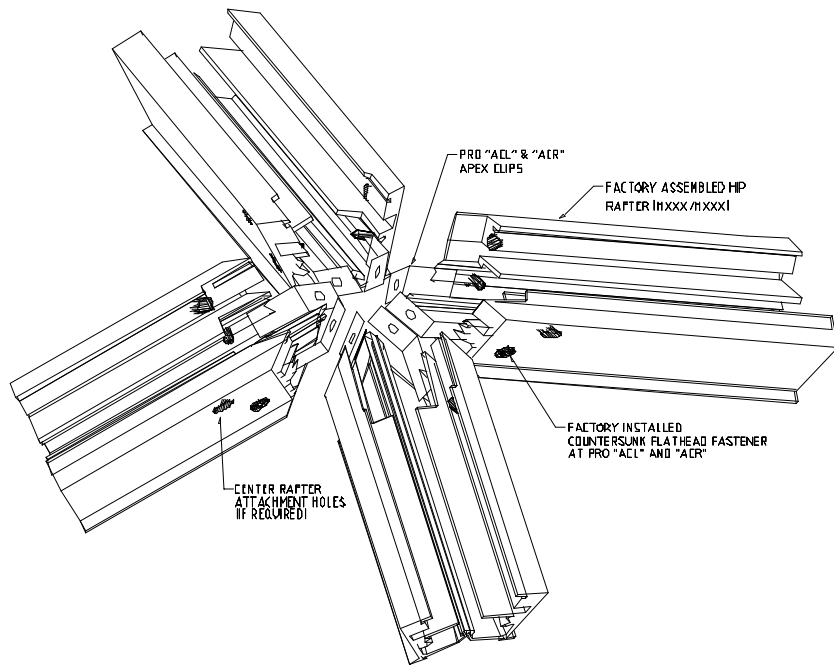

Diagram #5A – Hip rafter attachment @ apex

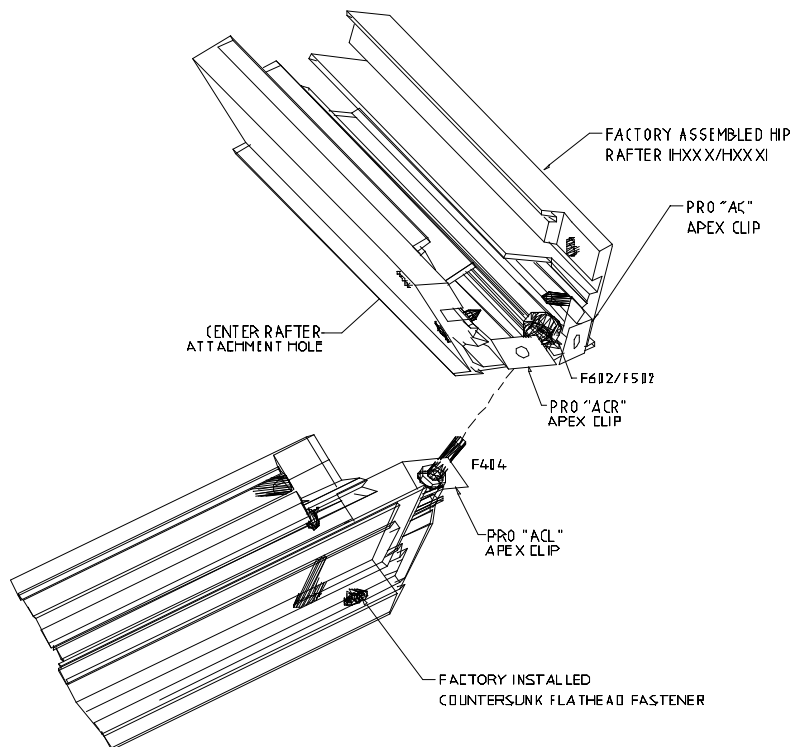
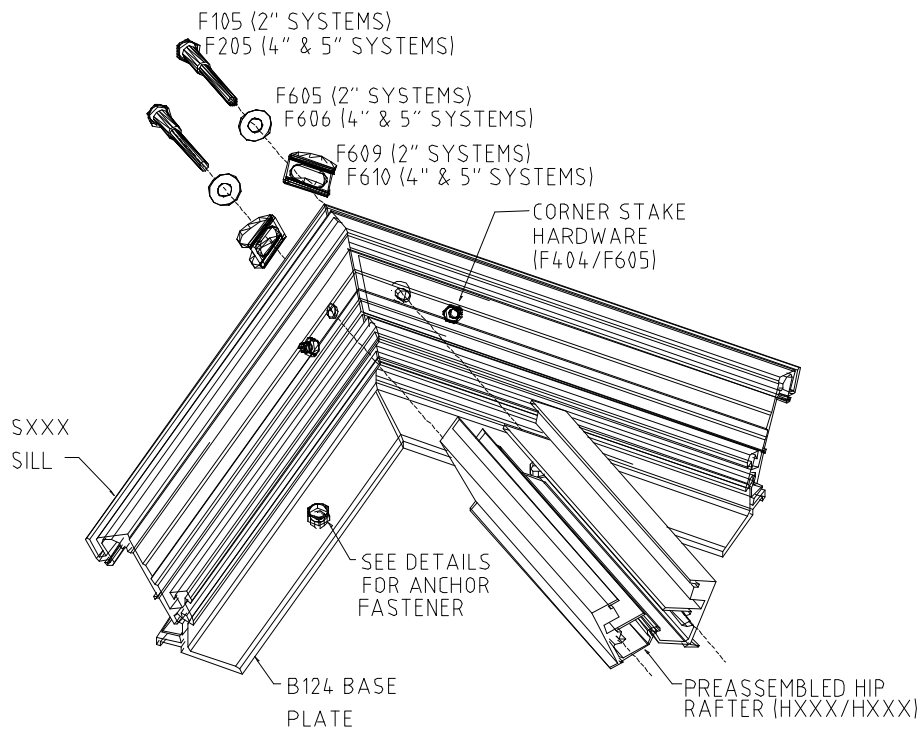

Diagram #5B – Hip rafter attachment @ apex

2. Attach hip rafter to sill assembly using hardware provided (See shop drawings).
(See diagram #6.)



STEP #4: Rafter and Purlin Attachment (If Applicable)

1. Slide self-centering stem (SG115/SG116) into appropriate rafter glazing pocket (see Diagram #7).

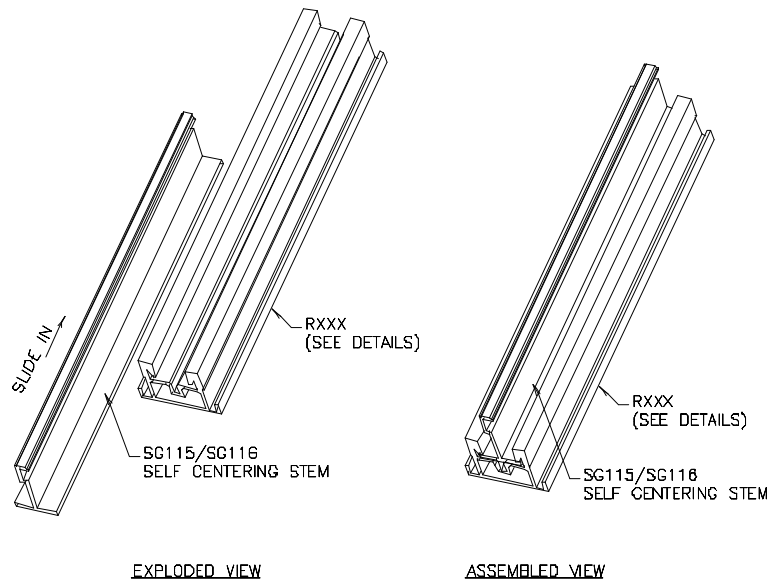

Diagram #7 – Attach self-centering cap support (SG115 or SG116)

2. Set main rafters (RXXX) into skylight. Attach rafters to sill assembly as shown on details using hardware provided (Fxxx/F6xx). Attach rafters to Hips and apex as shown on details using hardware provided (See Diagram #8).
3. Set purlins (PXXX) into skylight and attach to rafters by sliding pre-attached F114 into slot in rafter. Note: Pre attached F114 should be up the slope when installing (typical)(see Diagram #8). At hip connections pre-attached F114 in should be in the lower (down the slope) screw chase on purlin (see Diagram #8A).

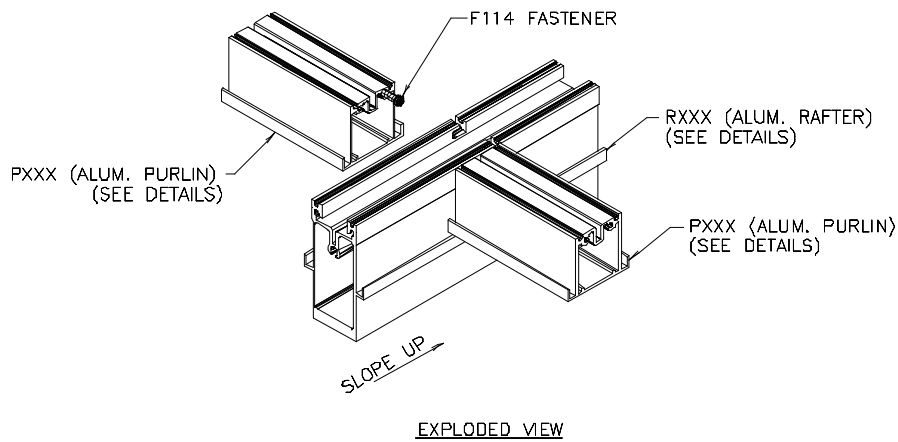
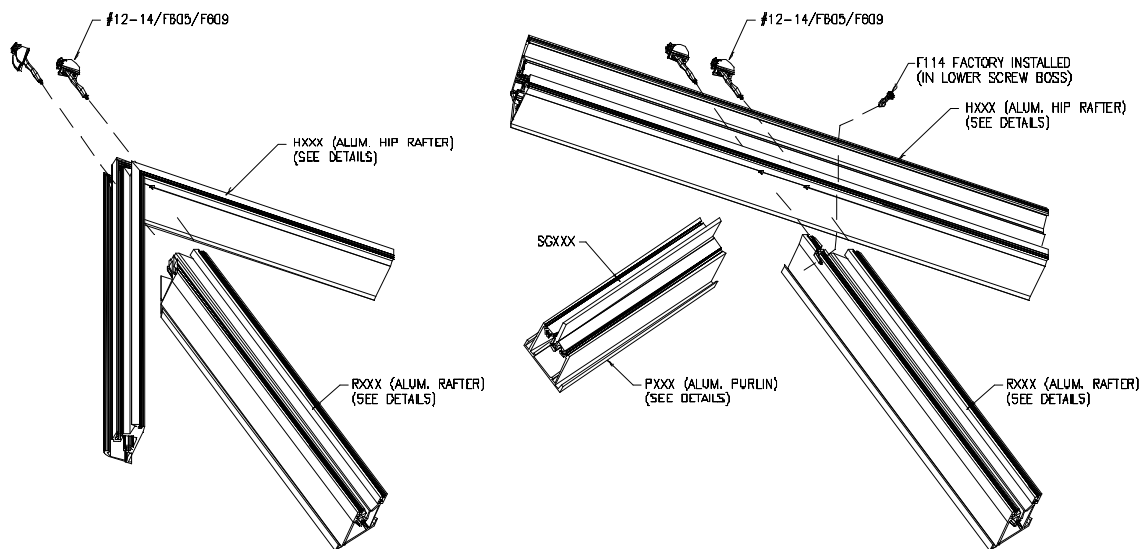

Diagram #8 – Purlin attachment @ Rafter



Center Rafter @ Apex

Jack Rafter and Purlin @ Hip

Diagram #8A – Rafter and Purlin Attachments

4. Trim all gaskets to fit and seal together using black silicone (F911) provided.

5. Snap in all SG (SGXXX) glazing supports onto appropriate horizontal members {sills(SXXX) and purlins(PXXX)}. Reference shop drawing details for assembly. Note: Drive SGXXX into frame with rubber mallet if required.

STEP #5: Glazing

Before attempting the glazing of the framework, make sure all gaskets are trimmed and properly installed flat on the frame and are sealed together to form a continuous water and air tight seal around the glass. Setting blocks should be placed at the quarter points of each opening to be glazed. The frame should be cleaned with denatured alcohol and rags. It is much easier to clean the frame prior to glazing. *It is especially important to clean the hip, ridge and sills “Heel Bead” (Reference Appendix “B”) surfaces with alcohol (Reference shop drawings) to ensure the subsequent structural silicone will properly adhere the glass to the frame.* Note that this cleaning should be done immediately prior to setting the glass and the subsequent caulking application. If the frame will be left overnight for example, be sure to clean the glazing surfaces on the second day immediately prior to glazing.

Identify the appropriate piece of glass for the opening you intend to glaze. Look at the glass labels closely, it is easy to confuse glass sizes and patterns i.e.: left and right triangles. If there is any confusion measure the glass and the intended opening to ensure its fit. The most important label is the one that says, “*Glaze this side in*” as the glass is not reversible. **DO NOT INSTALL GLASS BACKWARDS.** This is an important safety and performance issue.

Attach glazing cups on outside surface of glass (Make sure cups are fully pumped, secured and positioned for the easiest handling). Remove lite from crate and set edge on 2x4, wash 2” all around inside surface w/alcohol and remove all labels and pads. Be aware of glass edges at all times especially when setting glass onto frames it is very easy to chip the edge of the glass while moving it and setting it into the frame. A small chip can become a crack later on. If you are installing glass by hand (without a crane), it is important to practice safe-lifting procedures i.e.: using your legs not your back, see OSHA standards, as glass panels frequently weigh 100 to 200 pounds or more. Practice your glass handling procedures away from the frame to ensure your personal safety, and limit potential damage to the skylight or glass. Always set glass with the bottom edge against the setting blocks and then lay the top in. Take care to align it well so the edges do not contact the frame anywhere. If movement of glass on the frame is required, you must lift it off the gaskets slightly prior to moving it. If the glass is slid on the gaskets you can “roll” the gasket out of the groove, which means you will now have to remove the glass entirely, reinstall the gasket and then reinstall the glass. The entire perimeter of the glass must always rest on a gasket. Install the bottom row of the glass first (at the sill), then progress up the next row if any. Take special care when glazing a second row of glass to not damage the first row of installed glass while working over top of it.

Always remain tied off !!!

1. Install glass setting blocks at $\frac{1}{4}$ points for each piece of glass (each point requires 1-G166 & 1-G167 to equal $\frac{3}{8}$ " thickness). (see Diagram #9).

Note: the $\frac{1}{4}$ points are from the outer edge of the glass.

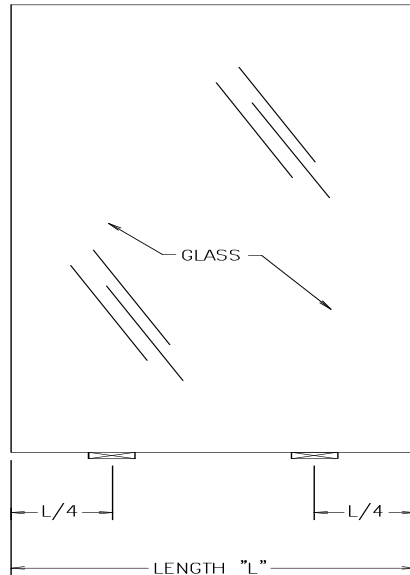

Diagram #9 – Setting Block Placement

2. Set in glass panels according to the Piece Mark sheet provided, making sure not to let the glass touch any metal or other glass.

IMPORTANT NOTE:

Insulated glass must be installed with laminated portion towards the inside of the building as shown by the “Glaze this side in” label on the glass panel.

STEP #6: Sealing the Skylight

The most critical step in the installation of a skylight is the sealant application. Take precautions to ensure a clean substrate and follow proper silicone joint design and tooling standards as described in these assembly instructions, the skylight shop drawings and Appendix “A” – Dow Corning Silicone Data Sheet.

All glass to glass joints as well as ‘heel beads’ require Dow 795 Black silicone. All glass to metal (frames and flashing) also require black silicone. Use colored silicone on metal to metal applications only (i.e. Framing intersections, flashing splices).

1. Clean all surfaces that will come into contact with silicone to insure proper adhesion. Reference SUBSTRATE CLEANING PROCEDURE as described in Appendix “A”.
2. Insert backer rod provided (F921) on purlins and sills between SG () and glass. Push backer rod into pocket to allow for 1/4” deep silicone joint (see shop drawings and detail below). Reference JOINT PREPERATION AND SEALANT APPLICATION as described in Appendix “A”.

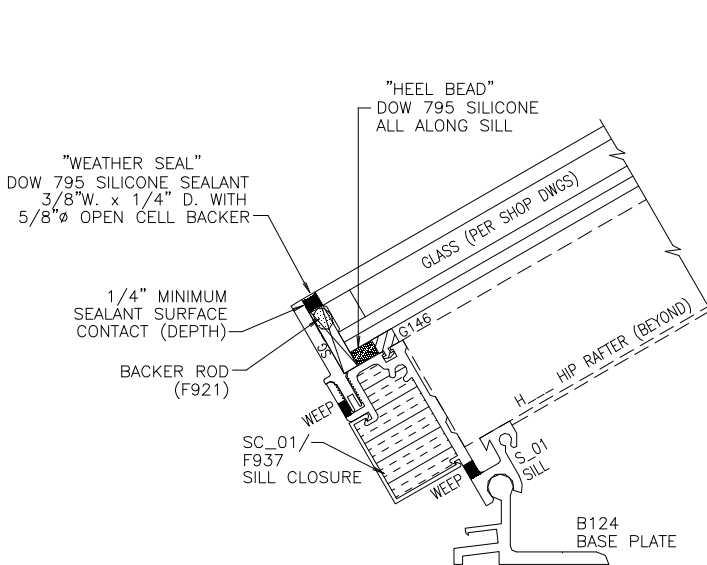

SILICONE DETAILS @ SILL

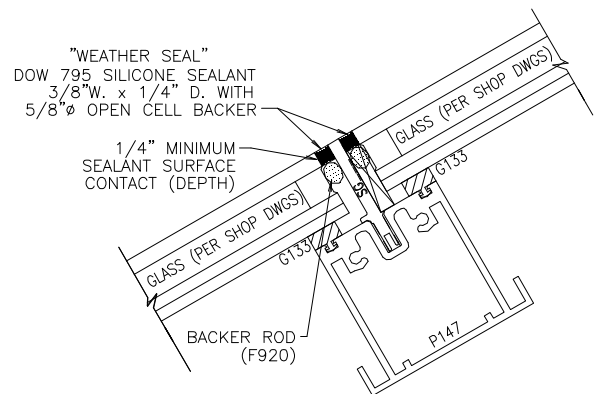

SILICONE DETAILS @ PURLIN

3. Insert backer rod provided (F920) on hips between glass and aluminum flashing. Push backer rod into pocket to allow for 1/4" deep silicone joint. Reference **JOINT PREPARATION AND SEALANT APPLICATION** as described in Appendix "A". (See diagram – 10 for hip flashing assembly).

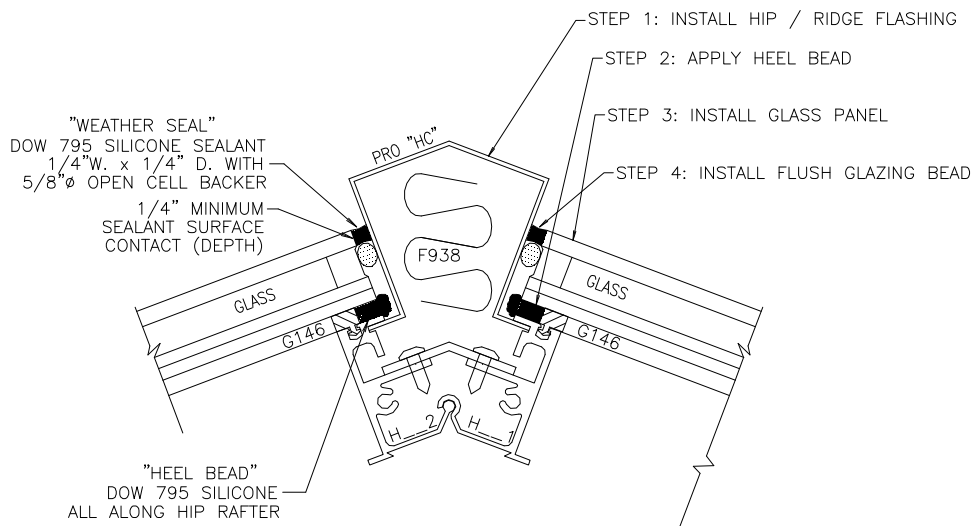
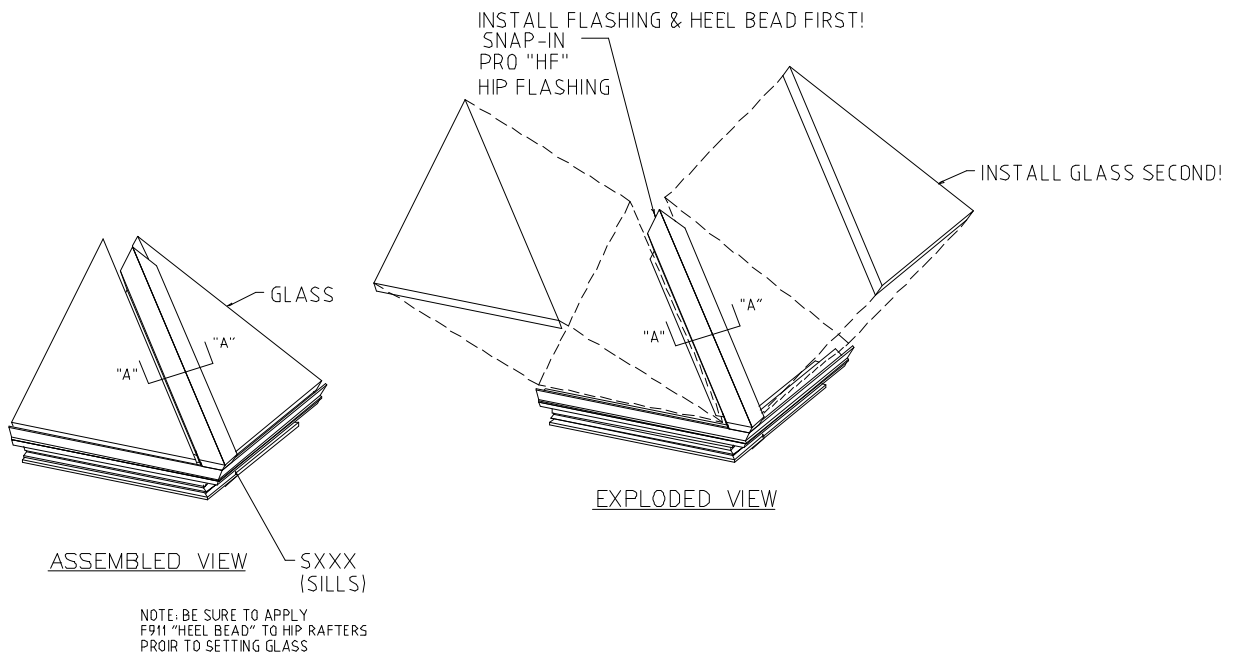

SECTION "A-A": SILICONE DETAILS @ HIP RAFTER

Diagram #10 – Hip Flashing Installation

4. Tape all joints prior to applying silicone. Use 1 ½” to 2” wide masking tape. Hold tape back from edge of joint 1/8-1/16”. Tape both sides of all joints, making sure there are no ripples or bubbles in the tape.
5. Fill joint generously with black silicone provided (F911). Reference JOINT PREPARATION AND SEALANT APPLICATION as described in Appendix “A” and “B”. Tool the silicone joint (force the silicone down into the joint while keeping the top flush with the glass plane) to a smooth finished joint (Reference Appendix “A”). Note: Do not push top of silicone down below glass surface, this will cause water to puddle of the silicone joint which may eventually break down the silicone.
6. After silicone begins to cure carefully remove tape. Remove tape as soon as tooling is complete and silicone begins to cure. (Reference Appendix “A”).

STEP #7: Capping

1. Locate retainer caps (C116) and install on appropriate rafter as shown on Pc. Mark drawings provided. Attach with self-drilling and tapping hardware provided (F115). Note: maintain a 1/4" gap between retainer cap and aluminum flashing at hips (see Diagram #10 & 11), bottom of retainer cap(C116) should align with outside edge of SGxxx at sill (see Diagram #11).

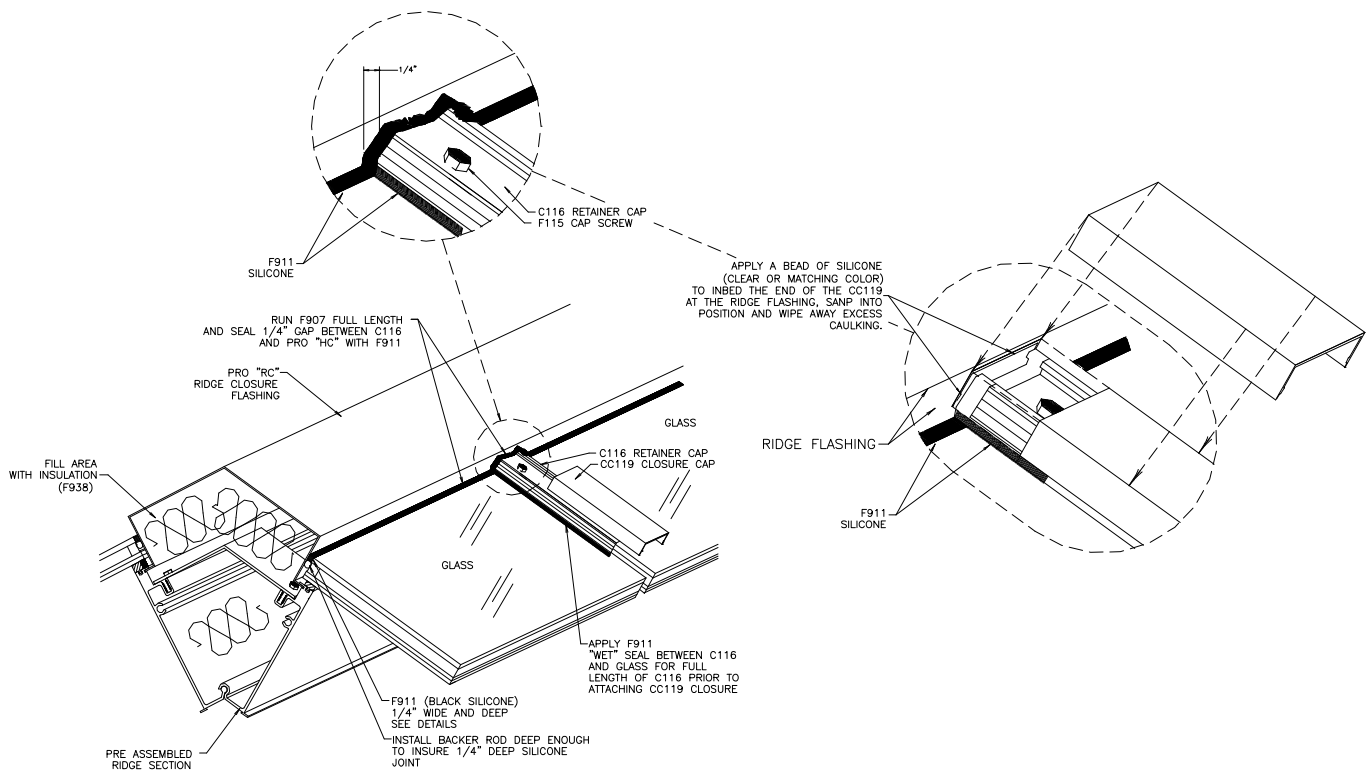

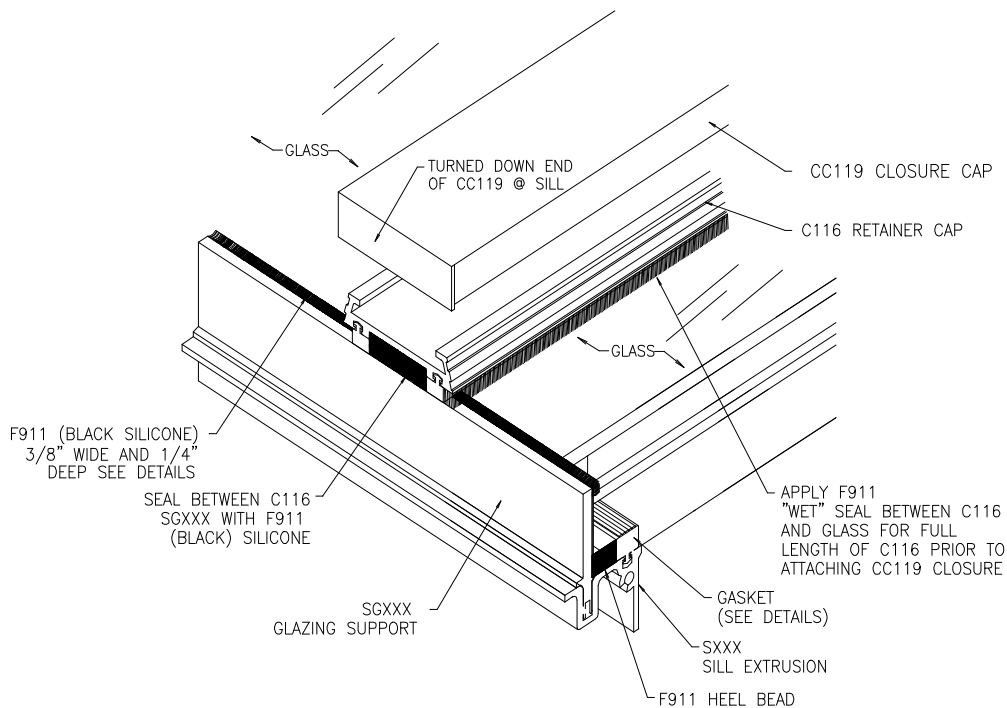

Diagram #12 –Cap installation @ sill

2. Using black silicone provided, seal ends of retainer cap to aluminum flashing at hip and to SG at sill. (Ref: Diagrams #11 & 12).
3. Apply wet-seal: Tape glass along both sides of C116 retainer cap. Fill void between C116 and glass with continuous sealant joint for full length of cap (Ref: Diagram #12 and details). Tool silicone and remove as described on appendix "A".
4. Locate snap-on Closure Caps (CC119) and attach to appropriate retainer cap as shown on Pc. Mark drawings provided. Use rubber mallet or wood block to protect finish when attaching.

STEP #8: Flashing

1. Using matching color silicone, seal all hip closure joints then apply the Apex Cap. Attach Apex Cap (Pro "AC") to top of skylight using silicone provided (color to match skylight).

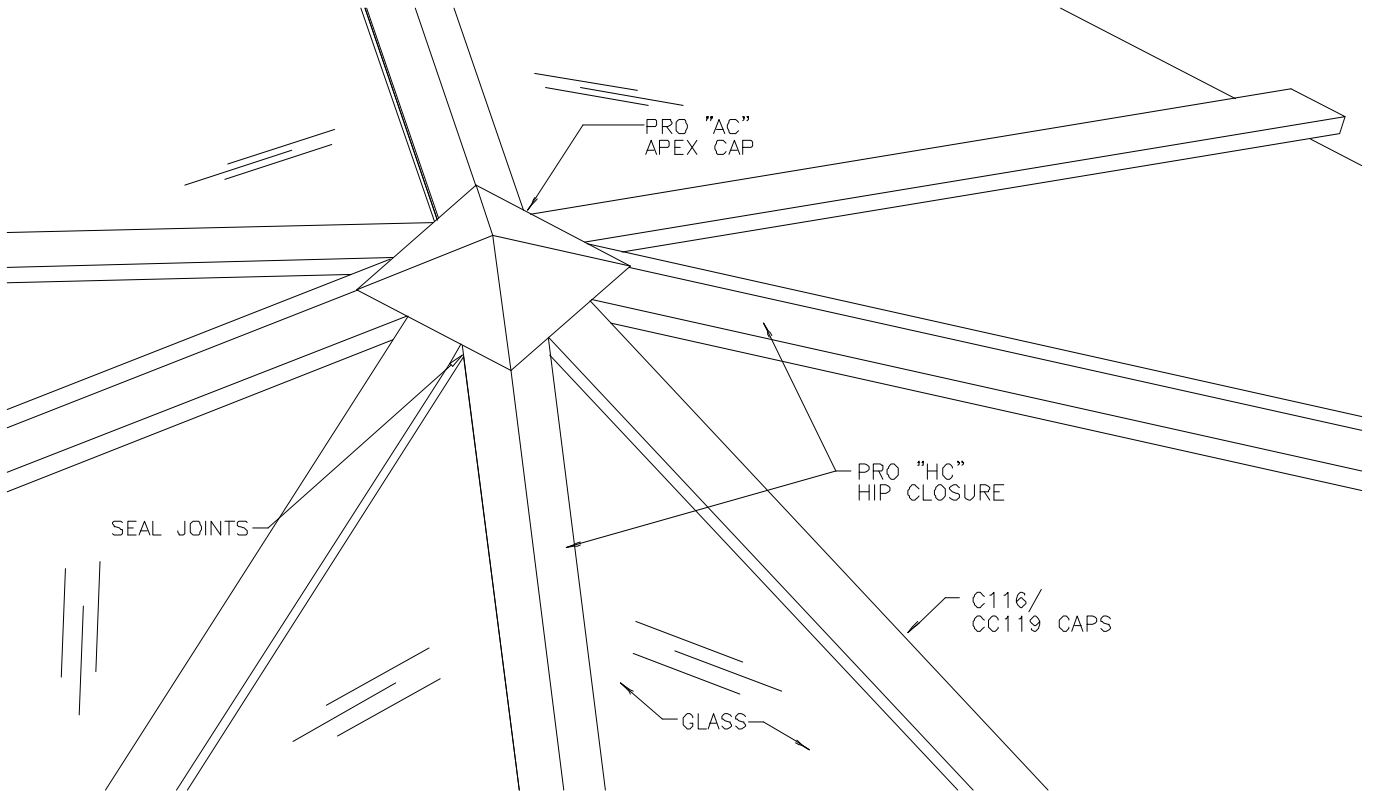

Diagram #13 – Apex Cap Assembly

2. Install insulated sill closure (SCXXX): Attach insulated sill closures to appropriate sills as shown on drawings (See Diagram # 14 & 14A). If required, splice closure panels using the same method as described (See Diagram #15).
Note: Semi-rigid insulation (F935) is factory installed and pre-assembled.

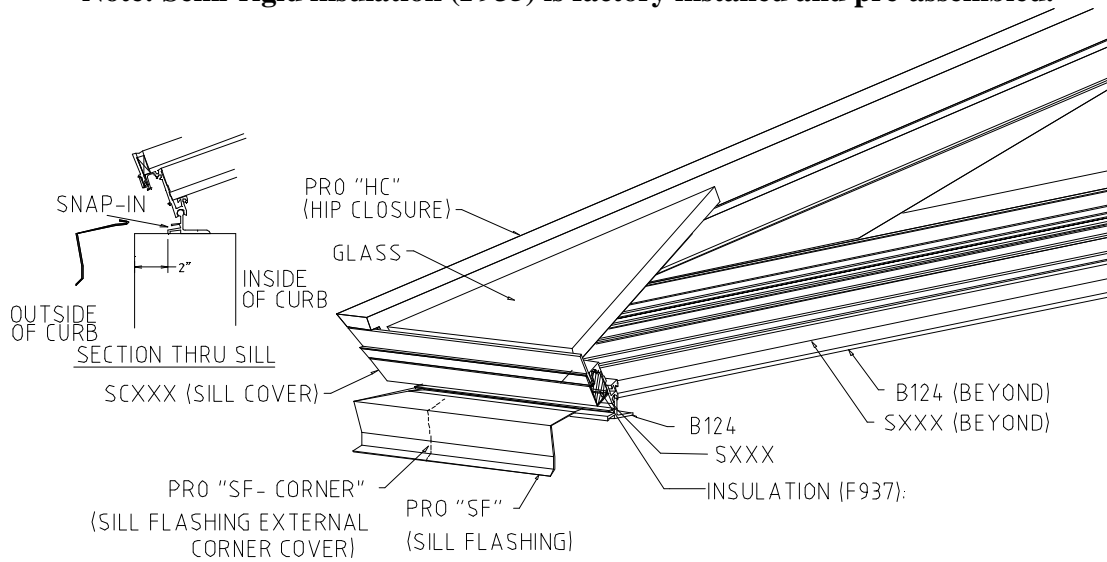

Diagram #14 – Sill Closure and Sill Flashing

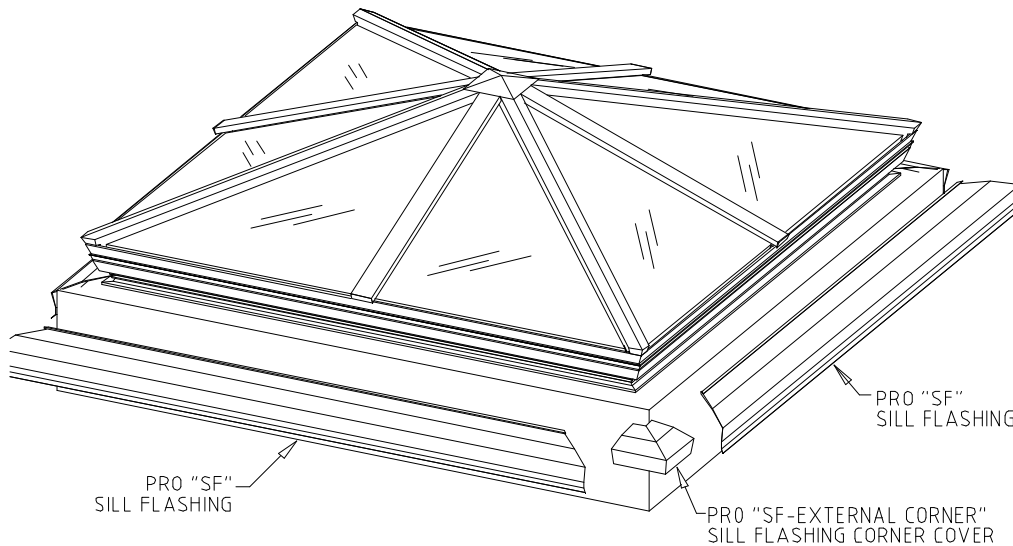
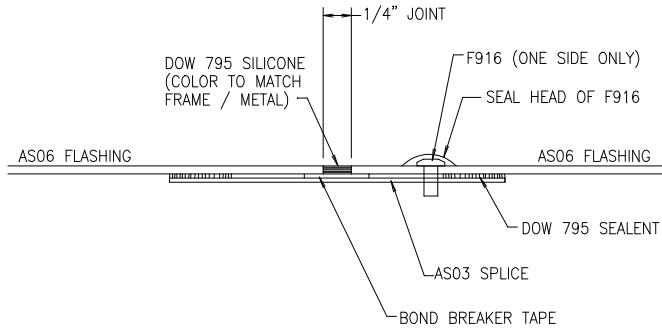

Diagram #14A – Sill Closure and Sill Flashing

3. Snap-in perimeter flashing (Pro "SF") as shown on drawings (See Diagram #14 & 14A). If splice are required splice per Diagram #15. To install sill Corner Covers, use silicone to match skylight color.

- Splice pieces of flashing together using silicone provided. Use colored silicone (to match finish of skylight) at the final exposed joint between the metal flashing (See Diagram #15).



SPLICE DETAIL FOR 0.060" THICK MATERIAL

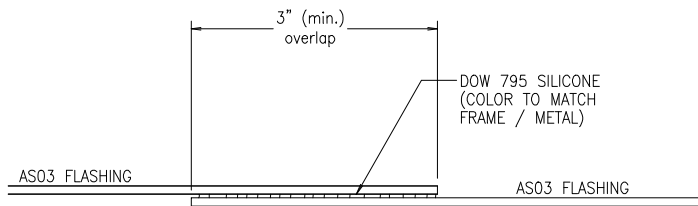

SPLICE DETAIL FOR 0.030" THICK MATERIAL

Diagram #15 – Flashing and Closure Splices

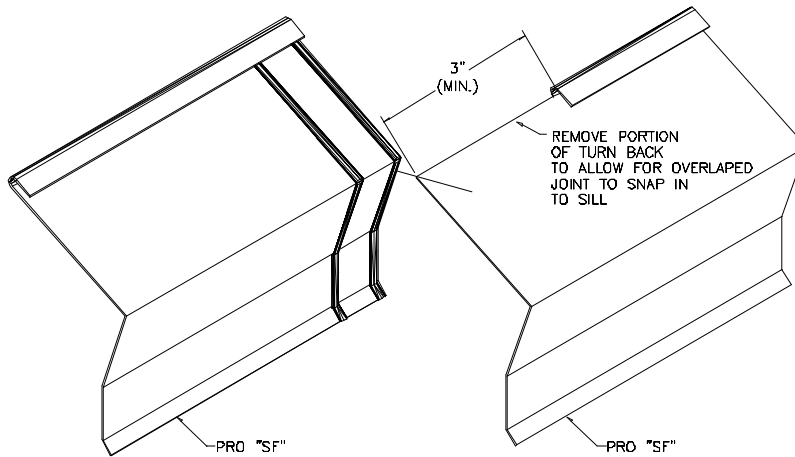
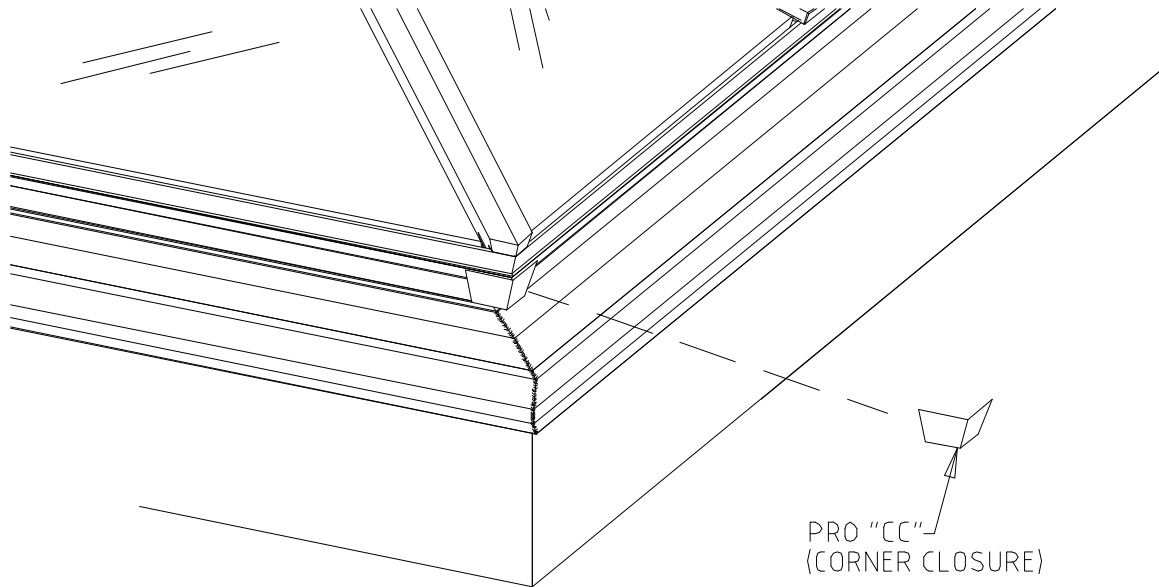

Diagram #15A – View of overlap flashing joint

5. Attach corner covers Pro "CC" with Dow-795 Silicone (color to match skylight) to back side of Pro "CC" prior to attaching to provide a weather tight seal. (See Diagram 16)



ASSEMBLED VIEW

Diagram #16 – Finished Corner

LIST OF APPENDICIES

APPENDIX “A”	DOW CORNING 795 BUILDING SEALANT
APPENDIX “B”	GANA GLAZING MANUAL
APPENDIX “C”	CLEANING AND MAINTENANCE GUIDE